

RECOMMENDED PCB LAYOUT

Dimensional Information			
Part No.	Dimensions		
	A	B	C
4P	4.00	1.50	2.57
6P	5.00	2.50	3.57
8P	6.00	3.50	4.57

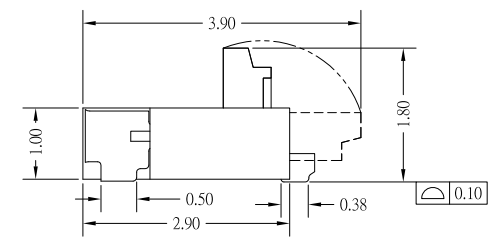
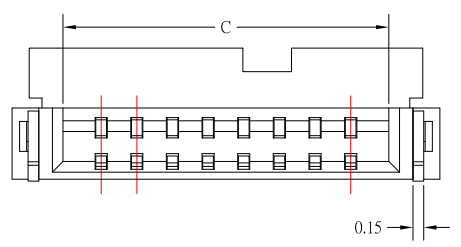

Note:

1. Material
 - 1.1: Housing: LCP, UL94-V0
 - 1.2: Actuator: LCP, UL94-V0
 - 1.3: Contact: Phosphor Bronze.
 - 1.4: LEG: Phosphor Bronze.
2. Plating
 - 2.1: Contact: Gold Plating
 - 2.2: LEG: Matte Tin Plating Over Nickel.
3. Rating:
 - 3.1: Operating Voltage: 50V AC/DC.
 - 3.2: Current Rating: 0.4A AC/DC.
 - 3.3: Contact Resistance: 30mΩ Max
 - 3.4: Insulation Resistance: 100MΩ Min
 - 3.5: Operating Temperature: -55°C~+85°C.

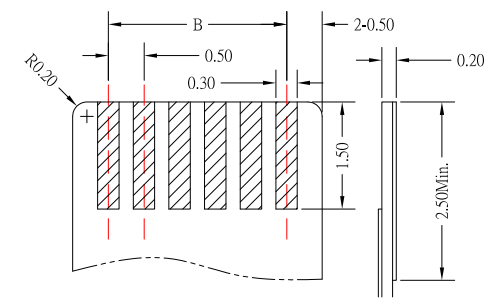
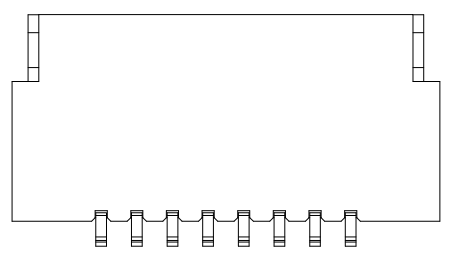

APPLICABLE FFC/FPC

東莞市高迪電子有限公司
DONG GUAN GAO DI ELECTRONICS CO., LTD

TOLERANCE UNLESS OTHERWISE STATED:
 Up to 5 ±0.2
 Above 5 ~ 15 ±0.3
 Above 15 ~ 30 ±0.4
 Above 30 ~ 50 ±0.5
 Angle ±0.3°

3RD. ANGEL'S

UNITS MM

DRAWN BY:	DATE	MAT'L	TITLE	CONNECTOR
Jack Lu	01/10/19		MODLE	0.5 FPC H:1.0 後掀式 0.2 CABLE 藍色蓋
CHECKED BY:	DATE	FINISH	DWG NO.	FPC05L2-10xx-C3-S304
Jacky Chen	01/10/19	SCALE	1 : 1	PART NO. FPC05L2-10xx-C3-S304
APPROVED BY:	DATE	SHEET NO.	1 of 1	
Tony Kao	01/10/19			

ITEM NO.	DESCRIPTION	DRAWN	DATE
4	更新MODLE	Jack	011019
3	更新PIN選項	Jack	010919
2	更新PIN選項	Jack	120418
1	更新MODLE	Jack	080917